

DIVISION: 31 00 00—EARTHWORK
Section: 31 60 00—Special Foundations and Load-Bearing Elements

REPORT HOLDER:

PIN FOUNDATIONS, INC.

EVALUATION SUBJECT:

DIAMOND PIER® DP-50 & DP-75 FOR BEARING PIN PIERS

1.0 EVALUATION SCOPE

Compliance with the following codes:

2018, 2015, 2012, 2009 and 2006 *International Residential Code®* (IRC)

Property evaluated:

Structural

2.0 USES

The Diamond Pier DP-50 and DP-75 bearing pin piers are used as foundations for the support of gravity loads for exterior decks, including covered decks, exterior porch decks, elevated walkways, stairway construction and accessory structures as defined in the IRC. The bearing pin piers are permitted for use in any of the weathering classifications defined in 2018 IRC Figure R301.2(4) or 2015, 2012, 2009 and 2006 IRC Figure R301.2(3).

3.0 DESCRIPTION

3.1 General:

The bearing pin piers consist of a factory-fabricated, pre-cast, diamond-shaped concrete head that has a galvanized steel anchor bolt precast into the center of the top of the head; and galvanized steel bearing pins which are jobsite-installed through holes precast in the head, and driven into the underlying soil. See Figure 1.

3.2 Materials:

3.2.1 Concrete Head: The DP-50 concrete head measures 10 inches (254 mm) by 10 inches (254 mm) by 11 inches (279 mm) tall, weighs approximately 50 pounds (22.7 kg), and is formed from air-entrained, normal-weight concrete. The DP-75 concrete head measures 11 inches (279 mm) by 11 inches (279 mm) by 12 inches (305 mm) tall, weighs approximately 75 pounds (34.0 kg), and is formed from air-entrained, normal-weight concrete. The air-entrained concrete has a minimum compressive strength of 5500 psi (37.9 MPa) at 28 days, and a total air content (percent by volume of concrete) of not less than

5 percent nor more than 7 percent, in accordance with IRC Section R402.2.

3.2.2 Precast Galvanized Steel Anchor Bolt: The galvanized steel anchor bolt that is precast into the center of the top of the DP-50 concrete head measures a minimum 1/2 inch (12.7 mm) in diameter and complies with ASTM A307 as Grade A. The galvanized steel anchor bolt that is precast into the center of the top of the DP-75 concrete head measures a minimum 5/8 inch (15.9 mm) in diameter and complies with ASTM A307 as Grade A.

3.2.3 Steel Bearing Pins: The four steel bearing pins supplied with each pier are made of Type E, Grade A (electric-resistance-welded), Schedule 40, galvanized steel pipe complying with ASTM A53. For the DP-50, pins have a nominal 1-inch diameter [1.315-inch (33.4 mm) outside diameter; 0.133-inch nominal wall thickness]; and have a minimum nominal length of 36 inches (914 mm) or 50 inches (1270 mm). For the DP-75 the pins have a nominal 1-1/4 inch diameter [1.66-inch (42.2 mm) outside diameter with a 0.140 nominal wall thickness]; and have a minimum nominal length of 50 inches.

4.0 DESIGN AND INSTALLATION

4.1 Design:

When installed in accordance with this report in minimum allowable 1500 psf (71.8 kPa) soils per IRC Table R401.4.1, the DP-50 bearing pin pier with 36 inch (915 mm) pins provides a 1.8 square foot (0.17 m²) bearing area for supporting gravity loads; the DP-50 bearing pin pier with 50 inch (1270 mm) pins provides a 2.4 square foot (0.23 m²) bearing area for supporting gravity loads; and the DP-75 bearing pin pier with 50 inch (1270 mm) pins provides a 2.8 square foot (0.26 m²) bearing area for supporting gravity loads.

When installed in accordance with this report in minimum allowable 2000 psf (95.8 kPa) soils per IRC Table R401.4.1, the DP-50 bearing pin pier with 36-inch (915 mm) pins provides a 1.8-square-foot (0.17 m²) bearing area for supporting gravity loads; the DP-50 bearing pin pier with 50-inch (1270 mm) pins provides a 2.2-square-foot (0.20 m²) bearing area for supporting gravity loads; and the DP-75 bearing pin pier with 50-inch (1270 mm) pins provides a 3.2-square-foot (0.30 m²) bearing area for supporting gravity loads.

4.2 Installation:

The site soil is prepared by digging a hole with a conical shape, approximately the shape of the base of the concrete head and slightly deeper than the pier itself, leaving loose soils directly below the head. The head is positioned in the

hole to its midpoint, and braced as needed to plumb. The bearing pins must then be slid through the holes in the concrete head, and driven into the soil as recommended in the Pin Foundations published installation instructions, leaving $\frac{3}{4}$ inch (19.1 mm) of the pin protruding from the upper surface of the pier. Once the dead loads have been applied to the pier, the length of the protruding bearing pin must be verified and adjusted as necessary to $\frac{3}{4}$ inch (19.1 mm). The exposed end of the bearing pins must then be capped and sealed as recommended in the Pin Foundations published installation instructions. The minimum spacing of the installed bearing pin piers is 3 feet (0.91 m) on center.

5.0 CONDITIONS OF USE

The Diamond Pier DP-50 and DP-75 bearing pin piers described in this report comply with, or are suitable alternatives to what is specified in the code indicated in Section 1.0 of this report, subject to the following conditions:

- 5.1 The bearing pin piers must be installed in accordance with the Pin Foundations, Inc. published installation instructions, the IRC and this report. In the event of a conflict between this report and the Pin Foundations, Inc. published installation instructions, this report governs.
- 5.2 Wood in contact with the concrete head and precast galvanized steel bolt must be protected against decay and subterranean termites in accordance with 2018, 2015, 2012 and 2009 IRC Sections R317 and R318, and 2006 IRC Sections R319 and R320, as applicable. Compatibility of the concrete head and precast galvanized steel bolt with wood treatments not described in 2018, 2015, 2012 and 2009 IRC Sections R317 and R318; and 2006 IRC Sections R319 and R320, as applicable must be established based on a current ICC-ES evaluation report on the wood treatment.
- 5.3 In areas requiring frost protection, exterior decks on bearing pin piers as described in Section 2.0 may be connected to and supported by a dwelling when approved by the code official. See IRC Section R403.1.4.1, Exception 3, as applicable.
- 5.4 Frost protection for accessory structures defined by the IRC is beyond the scope of this report, except free-standing accessory structures constructed in accordance with IRC Section R403.1.4.1, Exceptions 1 or 2, where frost protection is not required.

- 5.5 The bearing capacity of the site soil must be determined in accordance with IRC Table R401.4.1. If presumptive soil capacity cannot be assumed in accordance with the IRC Table R401.4.1, the code official may request a soils report.
- 5.6 The capacity of the bearing pin piers to resist lateral and/or uplift loads was not evaluated for this report.
- 5.7 Use of the bearing pin piers where soil constituents, changing water levels or other factors indicate possible deleterious effects on the pier foundation assembly, is beyond the scope of this report.
- 5.8 Use of the bearing pin piers is limited to structures regulated by the IRC.

6.0 EVIDENCE SUBMITTED

Data in accordance with the ICC-ES Acceptance Criteria for Bearing Pin Piers (AC336), dated June 2016 (editorially revised April 2019).

7.0 IDENTIFICATION

- 7.1 Each pallet of Diamond Pier DP-50 and DP-75 precast concrete heads is labeled with the Pin Foundations, Inc., name and address; the product name (Diamond Pier DP-50, or Diamond Pier DP-75); the evaluation report number (ESR-1895); the manufacturing date and lot number; and the phrase, "For Use with One- and Two-Family Dwelling Construction Only."

Each bundle of bearing pins is labeled with the Pin Foundations, Inc., name and address; the product name (Diamond Pier DP-50, or Diamond Pier DP-75); the evaluation report number (ESR-1895); and the phrase, "For Use with One- and Two-Family Dwelling Construction Only."

- 7.2 The report holder's contact information is the following:

PIN FOUNDATIONS, INC.
4810 PT. FOSDICK DRIVE NW, PMB 60
GIG HARBOR, WASHINGTON 98335
(253) 858-8809
www.pinfoundations.com

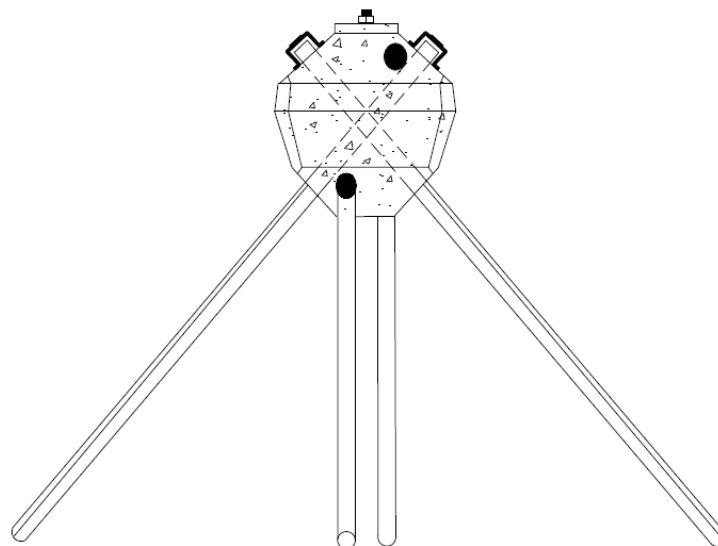

FIGURE 1—DIAMOND PIER DP-50 and DP-75

DIVISION: 31 00 00—EARTHWORK

Section: 31 60 00—Special Foundations and Load-Bearing Elements

REPORT HOLDER:

PIN FOUNDATIONS, INC.

EVALUATION SUBJECT:

DIAMOND PIER DP-50 & DP-75 FOR BEARING PIN PIERS

1.0 REPORT PURPOSE AND SCOPE

Purpose:

The purpose of this evaluation report supplement is to indicate that DIAMOND PIER DP-50 & DP-75 bearing pin piers, recognized in ICC-ES evaluation report ESR-1895, has also been evaluated for compliance with the code noted below.

Applicable code edition:

2019 *California Residential Code* (CRC)

2.0 CONCLUSIONS

CRC:

The DIAMOND PIER DP-50 & DP-75 bearing pin piers, described in Sections 2.0 through 7.0 of the evaluation report ESR-1895, complies with CRC Chapter 4, provided the design and installation are in accordance with the *International Residential Code*® (IRC) provisions noted in the evaluation report.

The products have not been evaluated under CRC Section R337 for use in the exterior design and construction of new buildings located in a Fire Hazard Severity Zone within State Responsibility Areas or any Wildland–Urban Interface Fire Area.

The products recognized in this supplement have not been evaluated for compliance with the *International Wildland–Urban Interface Code*®.

This supplement expires concurrently with the evaluation report, reissued December 2019 and revised January 2020.